



DB1000SA

User friendly Ice Pro control panel!



DB1000SA

Ice storage bin with automatic agitation to store and dispense cube ice into ice bags, carts, pails or Totes™. Exceptional labor-savings, sanitation and safety for foodservice operators. Up to 1000 lbs (454kg) storage capacity.

Labor-saving ice removal

- Eliminates the need to shovel or scoop ice from bin
- Automatic agitation cycle prevents ice from forming bridges – two rotating agitator bars keep ice loose and free flowing
- Foot pedal and push-button actuation standard with dispense rate of up to 120 lbs (55kg) per minute

Dispenses ice up to 1" (26mm) square into most carts and containers

- Adjustable bag stand accommodates ice bag sizes up to 20 lbs (9kg)
- Standard dispense chute compatible with carts to 29.5" (750mm) high
- Dispenses ice into smaller containers such as Totes or ice coolers

Easy to clean, easy to use

- Dispensing and agitating components easily removed for cleaning
- Removable, lockable clear window prevents unauthorized access to ice; provides for ice removal in power failures and for maintenance
- Maintenance access from the front and side
- Front assembly removes for installation through narrow doors

Semi-automatic bagging DB1000SA

- User-friendly controls with mode selection and variable dispense time
- Blower puffs bags open automatically for high volume, hands-free dispensing of bagged ice
- Bag holder pins for use with wire-wicket ice bags; pins adjust for ice bags 5" to 10" (127 to 254mm) on center
- Dispense timer for consistent filling of ice bags
- 8 lbs (3.6kg) bags of packaged ice can be filled by one person at a rate of 6-8 per minute
- Includes 250 8 lb (3.6kg) packaged ice bags and reorder information

Accessories

- Leg extension elevates unit 6.5" (165mm) for use with taller carts; includes adjustable bag stand to accommodate bag sizes up to 40 lbs (18kg)
- Reinforced top and drain pan assembly for Vogt icemakers
- 8 lb (3.6kg) ice bags (item# 00116434)
- 20 lb (9kg) ice bags (item# 00138370)
- Bostitch P-7 C-ring plier for closing bags (item# 00137711)
- Staples, aluminum blunt-end C-rings (item# 00137729)

Job: _____

Item: _____

U.S. Patent 6,685,053,
6,860,408 & 7,137,271
Other patents pending

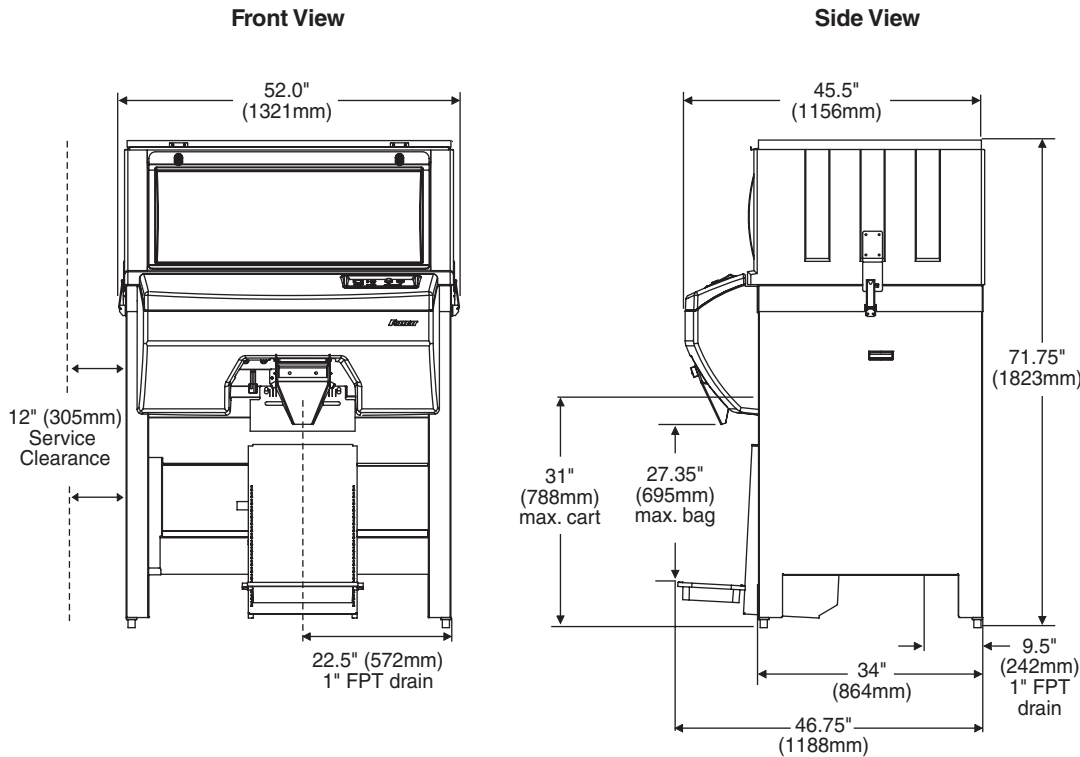

Plug
Configuration
NEMA 6-15



General Notes

Follett recommends installation of a floor drain with grate with all ice storage bins.

DB1000-SA only: Dispenser shall be equipped with blower function for automatically opening ice bags, timed dispense and holding pins for bags.

Model Number	Cubic Volume cu ft (m)	Max. Bin Capacity lb (kg) ¹	Width in (mm)	Depth in (mm) ^{2,3}	Height in (mm) ⁴	Req'd Door Access in (mm) ²	Approx. Ship Weight lb (kg) ²
DB1000	33.3 (.94)	1000 (454)	52.0 (1321)	45.5 (1156)	71.75 (1823)	34.25 (870)	704 (320)
DB1000SA	33.3 (.94)	1000 (454)	52.0 (1321)	45.5 (1156)	71.75 (1823)	34.25 (870)	704 (320)

Notes:

- 1 Computed on cubic volume of bin. Does not reflect voids that can occur due to pyramiding.
- 2 Add 2" (51mm) to depth and 10 lbs (4.5kg) to shipping weight when drain pan accessory used.
- 3 Dispense assembly removes if necessary for installation access through 36" (915mm) door opening.
- 4 Special top required for icemakers weighing more than 800 lbs (363kg). Add 2.125" (54mm) to height. Contact factory.

Electrical

220V, 60Hz, 1 ph, 5 full load amps

Required circuit – 220V, 60Hz, 1 ph, 15 amps

Wire in accordance with all local codes.

Follett reserves the right to change specifications at any time without obligation. Certifications may vary depending on country of origin.