

## GEM0450 - Pearl Ice® Maker



GEM0450 on IOD150

### Features

- Space saving 21" (533 mm) wide design.
- Produces up to 464 lbs (210 kg) of ice per day.
- Pearl Ice® soft, chewable ice crystals.
- Cools beverages faster and longer while maintaining flavors better.
- Decreased water and power usage compared to cube ice makers.
- SystemSafe load monitoring system constantly checks workload on gearbox shutting down system before a problem develops preventing costly repairs.
- Water Sensor eliminates low or no water failures and cannot be affected by adverse water conditions. Rugged stainless steel evaporator and auger ensures reliability.
- Rugged stainless steel evaporator and auger ensures reliability.
- Industrial-grade roller bearings and heavy duty gearbox provide years of trouble free service.

### Options & Accessories

Water Filters			
Ice Machine Model	Manifold		Inline
	System	Replacement	System
GEM0450	IFQ1	IOMQ (1)	N/A

### Ice Maker Warranty

Every Ice-O-Matic ice maker is backed by a warranty that provides both parts and labor coverage.

#### Parts & Labor

- Three years **Parts & Labor** for all Pearl Ice® ice maker parts.
- Five years **Parts** coverage on the compressor.

### Ice Form



### Bin Chart

Kits for Combining Wider Bins with Smaller Models

		Ice Storage Bins								
		Model No.	B25	B40	B42	B55	B100	B120	B150	B170
		Capacity	255 lbs (116 kg)	365 lbs (165 kg)	374 lbs (170 kg)	556 lbs (252 kg)	927 lbs (420 kg)	1193 lbs (541 kg)	1499 lbs (679 kg)	1866 lbs (846 kg)
		Width	30 in (762 mm)	30 in (762 mm)	22 in (559 mm)	30 in (762 mm)	48 in (1219 mm)	48 in (1219 mm)	60 in (1524 mm)	60 in (1524 mm)
Kits	GEM0450		KBT19	KBT19	KBT24	KBT19	KBT23	KBT23	N/A	N/A
	GEM0450 (2)		N/A	N/A	N/A	N/A	KBT22	KBT22	N/A	N/A

\*See Ice-O-Matic Price List for Adapter Kits to combine ice makers with most available ice/beverage dispensers.

GEM0450 Pearl Ice® Maker



Distributed By:  
 Commercial Refrigeration Service, Inc.  
 623-869-8881  
 or toll free (866) IceMakers  
 http://WWW.866IceMakers.COM



GEM0450 Pearl Ice® Maker

### Air Cooled

Please note: air-cooled units require 6" (152 mm) clearance for air intake and exhaust.

- A. Ice maker potable water in, 3/8" flare.
- B. Ice maker water out, 3/4" FPT.
- C. Electrical inlet.

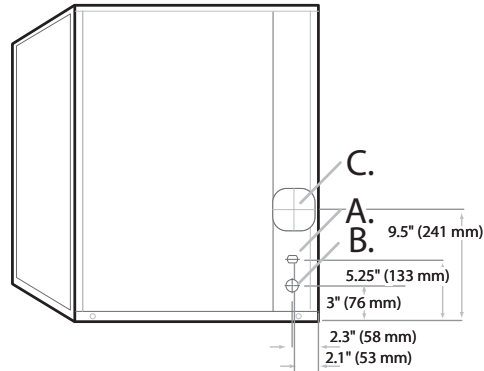
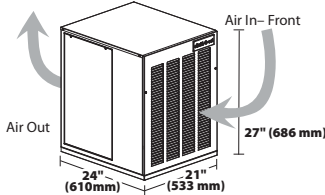

Rear View Air Cooled

### Water Cooled

- A. Ice maker water in, 3/8" flare.
- B. Ice maker water out, 3/4" FPT.
- C. Electrical inlet.
- D. Condenser water in, 3/8" (water cooled only).
- E. Condenser water out, 1/2" (water cooled only).

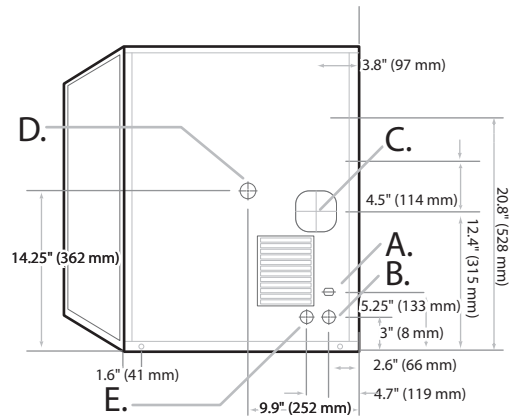

Rear View Water Cooled

### Operating Requirements

	Minimum	Maximum
Ambient Temp. Range Air	50°F (10°C)	100°F (38°C)
Water Temp.	40°F (4.4°C)	100°F (38°C)
Water Pressure	20 PSIG (1.4 BAR)	120 PSIG (8.3 BAR)

### Dimensions

All Models	
W x D x H (inches)	21 x 24 x 27
W x D x H (mm)	533 x 610 x 686

### Specifications

Model Number	Cond. Unit	Ice Production per 24hrs		Water Usage per 100lbs (45kg) of ice		kWH Used per 100 lbs (45 kg) of ice @ 90°F/ 32°C air 70°F/21°C water	Voltage	Min. Circuit Amps	Fuse Size	Approx. BTUs per hour
		70°F/21°C air 50°F/10°C water lbs (kg)	90°F/32°C air 70°F/21°C water lbs (kg)	Potable gal (l)	Condenser gal (l)					
GEM0450A	Air	464 (210)	354 (161)	12.0	-	5.31	115/60/1	16.0	20	5,600
GEM0450W	Water	508 (230)	429 (195)	12.0	68.5	4.11	115/60/1	14.4	20	5,600

NOTES:  
 Number of Wires: 3 (including ground)  
 Approx. Shipping Weight /lbs (kg): GEM0450A 205 (93) • GEM0450W 220 (110)  
 Refrigerant Type: R404A