

Indigo™ Series 522 Ice Cube Machine

Model: IR-0520A ID-0522A IY-0524A IR-0521W ID-0523W IY-0525W



Indigo Series i-522
Ice Machine on B-420 Bin

Designed for operators who know that ice is critical to their business, the Indigo™ Series ice machine's preventative diagnostics continually monitor itself for reliable ice production. Improvements in cleanability and programmability make your ice machine easy to own and less expensive to operate.

- **Space-Saving Design** – Up to 485 lbs. (220 kgs.) daily ice production and only 22" (55.88 cm) wide.
- **Intelligent Diagnostics** – provide 24 hour preventative maintenance and diagnostic feedback for trouble free operation.
- **Acoustical Ice Sensing Probe** – for reliable operation in challenging water conditions.
- **EasyRead Display** – communicates operating status, cleaning reminders, and asset information through a blue illuminated display.
- **Programmable Ice Production** – by On/Off Time, Ice Volume or Bin Level (with accessory bin level control) further improves energy efficiency and savings.
- **Easy to Clean Foodzone** – Hinged front door swings out for easy access. Removable water-trough, distribution tube, curtain, and sensing probes for fast and efficient cleaning. Select components made with AlphaSan® antimicrobial.
- **DuraTech™ Exterior** – provides superior corrosion resistance. Stainless finish with innovative clear-coat resists fingerprints and dirt.
- Available **LuminIce™ Growth Inhibitor** controls the growth of bacteria and yeast within the foodzone.

Specifications

BTU Per Hour:
 5,300 (average) 6,100 (peak)

Refrigerant:
 R-404A CFC-free

Operating Limits:

- Ambient Temperature Range:
 35° to 110°F (1.7° to 43.3°C)
 Water Temperature Range:
 35° to 90°F (1.7° to 32.2°C)
- Water Pressure Ice Maker
 Water In:
 Min. 20 psi (137.9 kPa)
 Max. 80 psi (551.1 kPa)

Ice Machine Electric

115/60/1 standard.
 (208-230/60/1 and 230/50/1
 also available)

Minimum circuit ampacity:

Air-cooled: 14.4 *1ph*
 Water-cooled: 13.5 *1ph*

Maximum fuse size:

Air-cooled: 20 *1ph*
 Water-cooled: 20 *1ph*



Ice Shape



Half Dice
 3/8" x 1 1/8" x 7/8"
 (.95 x 2.86 x 2.22 cm)



Dice
 7/8" x 7/8" x 7/8"
 (2.22 x 2.22 x 2.22 cm)



Regular
 1 1/8" x 1 1/8" x 7/8"
 (2.86 x 2.86 x 2.22 cm)





**i-522 on B-420 bin
 Storage Bin**

- Ⓐ Electrical Entrance (2) Options
- Ⓑ 3/8" (0.95 cm) F.P.T. Water Condenser Inlet (water-cooled units)
- Ⓒ 1/2" (1.27 cm) F.P.T. Water Condenser Outlet (water-cooled units)
- Ⓓ 1/2" (1.27 cm) Auxillary Base Drain Socket
- Ⓔ 3/8" (0.95 cm) F.P.T. Ice Making Water Inlet
- Ⓕ 1/2" (1.27 cm) F.P.T. Ice Making Water Drain
- Ⓖ 3/4" (1.91 cm) Bin Drain

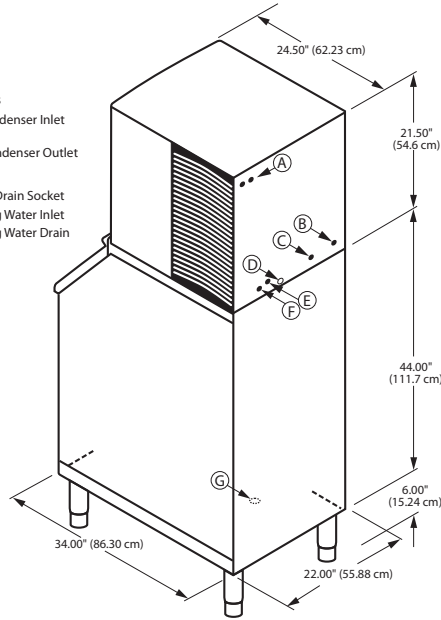

Installation Note
 Minimum installation clearance:
 Top/sides: 12" (30.50 cm)
 Back: 5" (12.7 cm)

Space-Saving Designs



	i-522 B-420	i-522 B-400*
Height	71.50" 181.61 cm	59.50" 151.13 cm
Width	22.00" 55.88 cm	30.00" 76.20 cm
Depth	34.00" 86.30 cm	34.00" 86.30 cm
Bin Storage	310 lbs. 140.7 kgs.	290 lbs. 131.7 kgs.

Height includes adjustable bin legs 6.00" to 8.00", (15.24 to 20.32 cm) set at 6.00" (15.24 cm).

* K-00141 bin adapter required.

Specifications

	Model	Ice Shape	Ice Production 24 Hours		Power Usage kWh/100 lbs. @90°Air/70°F	Water Usage/100 lbs. 45.4 kgs. of Ice	ENERGY STAR*
			70°Air/ 50°F Water	90°Air/ 70°F Water		Potable Water	
AIR-COOLED	IR-0520A	regular	415 lbs.	320 lbs.	7.23	23.8 Gal.	
			188 kgs.	145 kgs.		90.1 L	
	ID-0522A	dice	475 lbs.	335 lbs.	6.64	23.8 Gal.	★
			215 kgs.	152 kgs.		90.1 L	
WATER-COOLED	IY-0524A	half-dice	485 lbs.	360 lbs.	6.45	23.8 Gal.	★
			220 kgs.	163 kgs.		90.1 L	
	IR-0521W	regular	395 lbs.	350 lbs.	5.19	23.8 Gal.	NA
			179 kgs.	159 kgs.		90.1 L	
WATER-COOLED	ID-0523W	dice	460 lbs.	163 lbs.	5.09	23.8 Gal.	NA
			209 kgs.	170 kgs.		90.1 L	
	IY-0525W	half-dice	480 lbs.	395 lbs.	4.87	23.8 Gal.	NA
			218 kgs.	179 kgs.		90.1 L	

* Water-cooled Condenser Water Usage / 100 lbs. /45.4 kgs. Of Ice: 190 gal/ 719 L.

* Water-cooled models are excluded from ENERGY STAR qualification.

Order ice storage bin separately.

Accessories

LuminIce™ Growth Inhibitor
 reduces yeast and bacteria growth for a cleaner ice machine.



Bin Level Control
 Allows ice bin level to be automatically set. Built-in LED light illuminates bin.



Arctic Pure® Water Filters
 Reduces sediment and chlorine odors for better tasting ice.



AuCS®
 schedules and performs routine ice machine cleaning automatically.

