



RN-Series 1400 Nugget Ice Machine

Models

RN-1408A

RN-1409W



RN-1408A Nugget Ice Machine on B-570 Bin



RN-1408A Nugget Ice Machine on Servend SV-250 Dispenser

Standard Features

- Up to 1490 lbs. (676 kgs) daily ice production.
- Only 30" (76.2 cm) wide.
- Evaporator is designed for maximum quality and operating life.

Warranty

- 3-year parts.
- 2-year labor.
- Compressor parts for 5 years and labor for 2 years.

Specifications

BTU Per Hour:

Air-cooled: 16,000
 Water-cooled: 16,400

Compressor:

Nominal rating: 2 HP

Refrigerant: R404A

Cupra-Nickel Condenser:
 (Water-cooled models)
 Adds protection from
 corrosive water elements.

Operating Limits:

- Ambient Temperature Range:
 50°-100°F (14.4°-37.8°C)
- Water Temperature Range:
 45°-90°F (7.2°-32.2°C)
- Water Pressure Ice Maker
 Water In:
 Min. 20 psi (137.9 kPa)
 Max. 70 psi (483 kPa)

Ice Machine Electric

208-230/60/1 ice machines are factory pre-wired with a 7' (2m) power cord and NEMA 6-20 right angle plug configuration.

Total Amps: Air-cooled: 12 amps
 Water-cooled: 12 amps

Maximum fuse size: Air- and Water-cooled: 20 amps

Ice Shape

- Nugget Ice provides a softer, chewable texture while still providing maximum cooling effect.
- 5/8" (1.59 cm) diameter cylindrical-shaped nugget with average length of approximately 1" (2.54 cm).





RN-Series 1400 Nugget Ice Machine

RN-1400 on B-570 Storage Bin

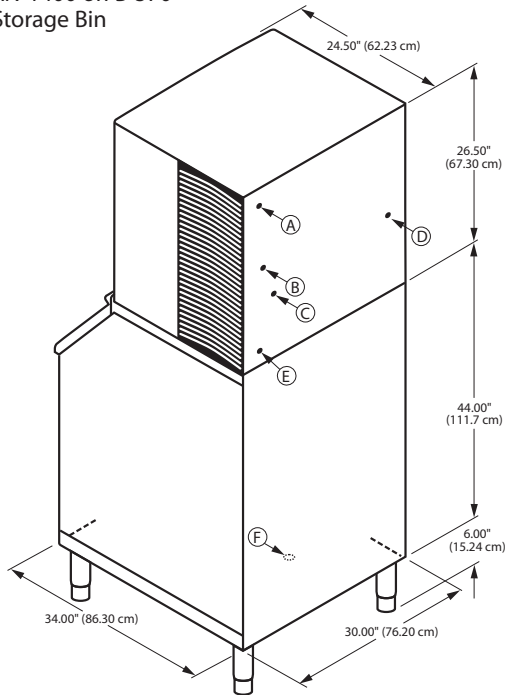

- Ⓐ 3/8" F.P.T. Ice Making Water Inlet
- Ⓑ 1/4" F.P.T. Water Condenser Outlet (water-cooled units)
- Ⓒ 1/4" F.P.T. Water Condenser Inlet (water-cooled units)
- Ⓓ Electrical Entrance
- Ⓔ 3/4" M.P.T. Ice Making Water Drain
- Ⓕ 3/4" Bin Drain

Installation Note -

Minimum installation clearance: Top/sides: 8" (20.32 cm), back: 5" (12.7 cm).

Dispenser Note -

Verify with the dispenser manufacturer that the correct agitator and deflector kit for nugget ice dispensing is included with your dispenser purchase.

Space Saving Designs



	RN-1400 B-570	RN-1400 B-970*
Height	76.50" 194.30 cm	76.50" 194.30 cm
Width	30.00" 76.20 cm	48.00" 121.92 cm
Depth	34.00" 86.30 cm	34.00" 86.30 cm
Bin Storage	430 lbs. 195 kgs	710 lbs. 322.2 kgs

*K-00370 adapter required with B-970 bin.

Height includes adjustable bin legs 6.00" to 7.00", (15.24 to 17.78 cm) set at 6.00" (15.24 cm).

Air Flow Top View

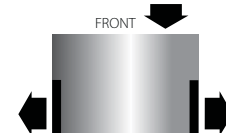

Specifications

	Model	Ice Shape	Ice Production 24 Hours		Power Usage kWh/100 lbs.@90°Air/70°F	Water Usage/100 lbs. 45.4 kgs of Ice	
			70°Air/ 50°F Water	90°Air/ 70°F Water		Potable Water	Condenser Water
AIR-COOLED	RN-1408A	Nugget	1289 lbs.	986 lbs.	5.53	13.2 Gal.	-
			585 kgs	447 kgs		50 L	-
WATER-COOLED	RN-1409W	Nugget	1490 lbs.	1318 lbs.	3.76	13.2 Gal.	176 Gal.
			676 kgs	598 kgs		50 L	668 L

Order ice storage bin separately. "A", or "W" following model number indicates "Air", or "Water" condensing unit. Will not accept AuCS accessory.

Distributed By:
Commercial Refrigeration Service, Inc.
<http://www.IceCubes.NET>
toll free: 866-IceMakers
(866) 423-6253
(623) 869-8881