

RF0650 Flake Ice Machine



Model RF0650A
Flake Ice Machine
on B-570 Bin

Distributed by:
Commercial Refrigeration Service, Inc.
<http://www.IceCubes.NET>
toll free 866 IceMakers
866 423-6253
623 869-8881

- Up to 688 lbs. (312 kgs.) daily flake ice production.
- High load capacity bearings for enhanced reliability.
- Heavy duty stainless steel cabinet resists corrosion.

Warranty

- 3-year Parts
- 2-year Labor
- Compressor parts for 5 years and labor for 2 years.



ISO 9001:2000
Quality System
Certified

America's #1 Selling Ice Machine

Ice Cube & Flake Machines • Ice Storage Bins • Ice Dispensers

Manitowoc

Manitowoc RF0650 Flake Ice Machine

AIR-COOLED	Model	Ice Shape	Ice Production 24 Hrs.		Power kWh/ 100 lbs. 90°/70°F	Potable Water Usage (100 lbs./ 45.4 kgs. of Ice)
			70° Air/ 50°F Water	90° Air/ 70°F Water		
			RF0650A	Flake		

Ice Machine Electric

208-230/60/1 standard. (230/50/1 also available.)

Minimum circuit ampacity: 7.3 amps.

Maximum fuse size: 15 amps.

HACR-type circuit breakers can be used in place of fuses.

Specifications

BTU Per Hour:
7,700 (average)

Compressor:
Nominal rating: 1 HP

Refrigerant: R-404A

Operating Limits:

- Ambient Temperature Range:
50°-110°F (10°-43°C)
- Water Temperature Range:
37°-90°F (3°-32°C)
- Water Pressure Ice Maker
Water In:
Min. 14 psi (96.5 kPa)
Max. 80 psi (551.6 kPa)

Standard Equipment

K-00404 30" B-Style Bin Adapter

Accessories

K-00405 48" B Style Bin Adapter*

*adapter not for use with Large Capacity Bins.

Air Flow Overhead View

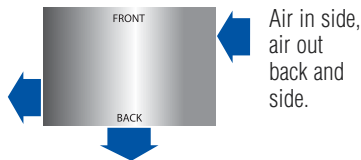

Distributed by:
Commercial Refrigeration Service, Inc.
<http://www.IceCubes.NET>
toll free 866 IceMakers
866 423-6253
623 869-8881

Space-Saving Designs

RF0650
B-570



Height	77.56" 197.00 cm
Width	30.00" 76.20 cm
Depth	34.00" 86.36 cm
Bin Storage	430 lbs. 195 kgs.

Height includes adjustable bin legs 6.00" to 7.00", (15.24 to 17.78 cm) set at 6.00" (15.24 cm).

Ice Shape

Flake ice is small hard bits of ice ideally suited for presentation applications.

Ice shown actual size



RF0650 on B-570 Storage Bin

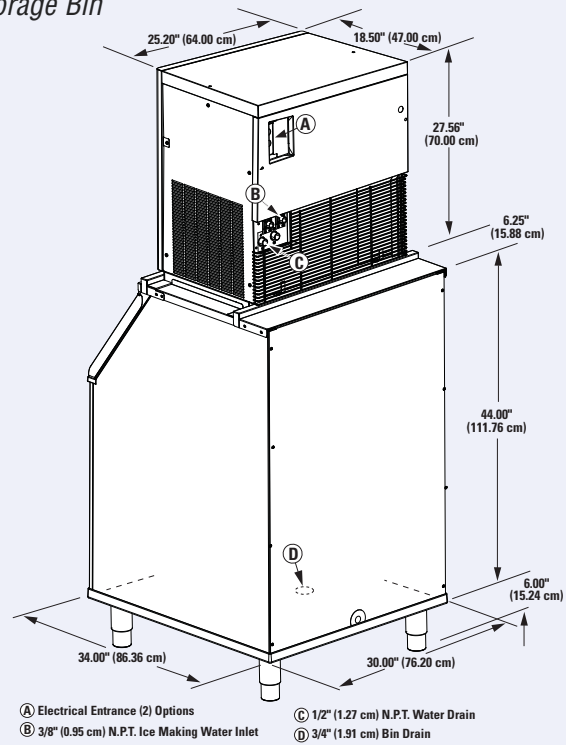

Installation Note - Minimum installation clearance:
Top/sides: 8" (20.32 cm), back: 5" (12.70 cm).



We are committed to protecting the environment and its resources. For up-to-date product data always view an electronic version on our web site.



MANITOWOC ICE
2110 South 26th Street, P.O. Box 1720
Manitowoc, WI 54221-1720, USA
Ph: 920-682-0161 • Fax: 920-683-7589
Visit us online at www.manitowocice.com

