

SCOTSMAN

TOUCHFREE® AIR & WATER COOLED NUGGET ICE MAKER / DISPENSER

MDT5N40

24 HOUR ICE PRODUCTION

Based on Air/Water Temperatures	Air-Cooled		Water-Cooled	
	70°/50° lbs./kg.	90°/70° lbs./kg.	70°/50° lbs./kg.	90°/70° lbs./kg.
MDT5N40	523/237	409/186	525/238	455/208

YOU'LL VALUE OUR IMPROVED TOUCHFREE® ICE MAKER / WATER DISPENSERS

- Sleek, European design with attractive rounded corners and informative instruction labels.
- Up to 25% less fan noise allows installation of the unit in the quietest hallways.
- TouchFree actuation provides convenient one-hand operations and eliminates the risk of cross contamination.
- Flexible utility location.
- Makes and dispenses soft, chewable nugget ice.

WARRANTY *See your dealer for complete warranty details.*

- 2 years parts on all components.
- 2 years labor on all components.
- 5 years parts on compressor.

Distributed By:
Commercial Refrigeration Service, Inc.
<http://www.IceCubes.NET>
866-IceMakers (866-423-6253)
623-869-8881



NUGGET ICE

A consumer preference, soft, chewable nugget ice is versatile and slow-melting. Nugget ice helps to cool drinks rapidly and stay cool longer.



SANITARY, ONE HAND OPERATION

Easily fills various sizes and types of containers.



DMS21 STAND

26" x 21" x 36"
Stainless Steel.

CERTIFIED
ISO
9001:2000

This product qualifies for the following listings:



Scotsman®

Ice Maker/Dispenser Specifications

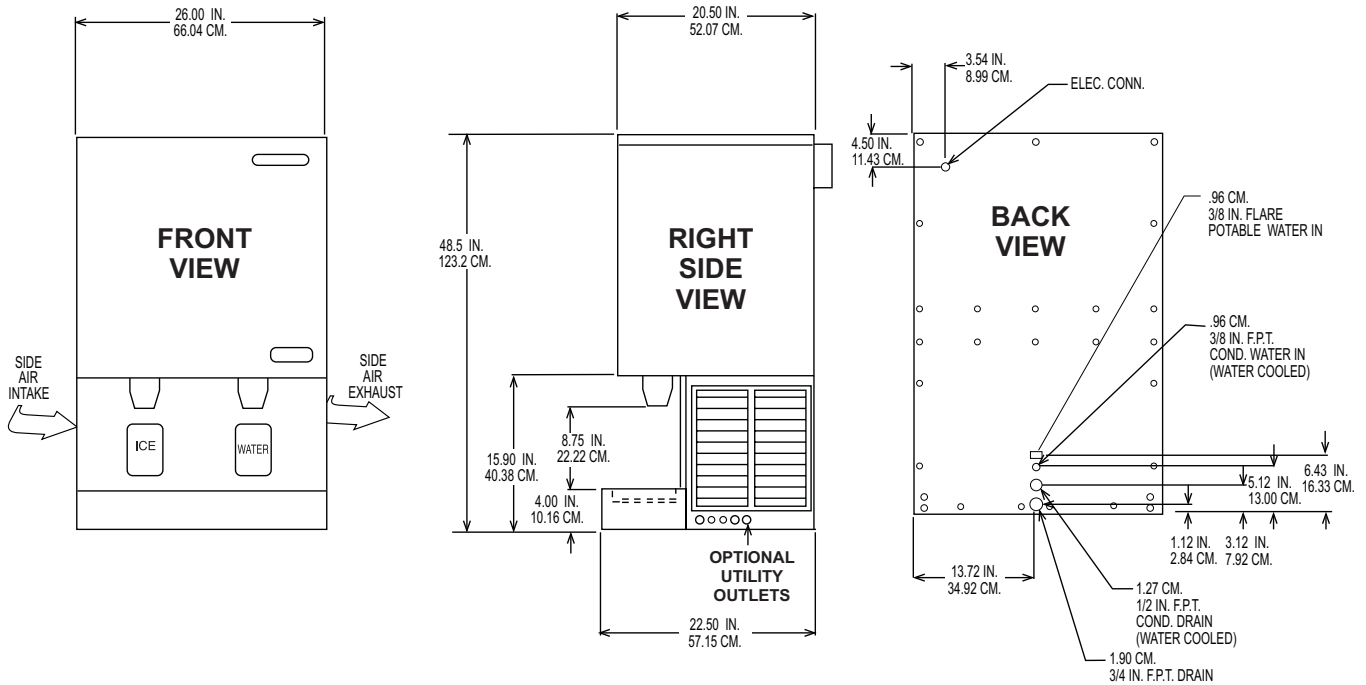

INSTALLATION NOTE: Allow 6" minimum space at sides and back for ventilation and utility connections.

All models: Dimensions: W x D x H Unit: 26" x 22 1/2" x 48 1/2" Shipping Carton: 30" x 24" x 53"

Model Number	Condenser Unit	Bin Cap. lbs./kg.	Basic Electrical Volts/Hz/Phase	Max. Fuse Size or HACR Circuit Breaker	Comp. HP	Circuit Wires	Min. Circuit Ampacity	Shipping Weight lbs./kg.	Power Consumption KWH/100 lbs. 90°F/70° F	Water Usage Gallons/100 lbs. Potable 90°F/70° F	Condenser 90°F/70° F
MDT5N40AS-1B	AIR	40/18	115/60/1	25	1/2	2	19.3	280/127	5.4	12	-
MDT5N40WS-1B	WATER	40/18	115/60/1	20	1/2	2	17.8	280/127	4.0	12	97.0

All units are stainless steel.
 Refrigerant: R-404A.

OPTIONS:
 KSP5: Splash panel kit to be used when the MDT5N40 is installed above a permanent sink and the sink assembly is not used.
 DMS21B: Machine stand for MDT5N40.
 Measurements: (W x D x H) 26" x 22 1/2" x 48 1/2" includes 6" legs.
 KWB3: Wall mounting kit.

IMPORTANT OPERATING REQUIREMENTS:

	Minimum	Maximum
Air Temperatures	50°F (10°C)	100°F (37.7°C)
Water Temperatures	40°F (4.4°C)	100°F (37.7°C)
Water Pressures	20 PSIG	120 PSIG
Electrical Voltage	-5%	+10%

ICE VENDING CAPACITY

PEAK VENDS PER HOUR*

Model	Bin Storage lb./kg.	1 Hour Recovery Cap. lb./kg.	Number of Vends Per Hour from Full Bin + Recovery = Total Vends											
			2 fl. oz. Bin	2 fl. oz. Recovery	Total 2 fl. oz. Vends	4 fl. oz. Bin	4 fl. oz. Recovery	Total 4 fl. oz. Vends	6 fl. oz. Bin	6 fl. oz. Recovery	Total 6 fl. oz. Vends	8 fl. oz. Bin	8 fl. oz. Recovery	Total 8 fl. oz. Vends
MDT5N40A	40/18	22/10	640	+ 349	= 988	320	+ 175	= 494	213	+ 116	= 330	160	+ 87	= 247
MDT5N40W	40/18	22/10	640	+ 350	= 990	320	+ 175	= 495	213	+ 117	= 330	160	+ 88	= 248

1 lb. apx. = 32 fl. oz.
 *Based on 70° Air and 50° Water Temperatures.

Scotsman's ice machines are not designed for outdoor installations.

Machine requires voltage indicated on rating name plate. Failures caused by improper voltage are not considered factory defects. Extended periods of operation at temperatures exceeding limitations constitutes misuse under the terms of Scotsman Manufacturer's Limited Warranty, resulting in a loss of warranty coverage. Specifications and design are subject to change without notice.

Consult Your Local SCOTSMAN Representative At:

YOU'LL VALUE THE DIFFERENCE™

775 Corporate Woods Parkway • Vernon Hills, IL 60061 • 1-800-SCOTSMAN • Fax: (847) 913-9844
 Visit our website at: www.scotsman-ice.com • E-mail: customer.service@scotsman-ice.com

Distributed By:
 Commercial Refrigeration Service, Inc.
<http://www.IceCubes.NET>
 866-IceMakers (866-423-6253)
 623-869-8881

Scotsman®