

NEW Horizontal Open Display Cases - Slim Line Top Display Dry Case Combination Models



Distributed By:
Commercial Refrigeration Service, Inc.
<http://WWW.IceCubes.NET>
623-869-8881 or toll free 866-IceMakers

FEATURES / BENEFITS

- **ENVIRONMENTAL FRIENDLY, EFFICIENT REFRIGERATION SYSTEM**
Turbo Air's refrigerators are designed with oversized and balanced environmental friendly R-134A (CFC Free) refrigeration. These include large evaporators and condensers for fast cooling and balanced temperature throughout the cabinet.
- **ATTRACTIVE GLASS SIDED ELEGANT EURO DESIGN**
Glass front shield and side walls optimize the merchandiser's display effects of fresh salads, sandwiches, desserts and beverages. Its elegant contemporary euro design will enhance any store application.
- **DESIGNED TO OPTIMIZE IMPULSE SALES**
Ideal for eye-catching displays and convenient access with fast service in high traffic area.
- **NON-PEEL, DURABLE ANTI-RUST COATING ON THE EXTERIOR REDUCES FINGERPRINTS**
- **TOP DISPLAY DRY CASES (TOMD-H) AVAILABLE IN ALL SIZES-OPTIONAL**
- **300 SERIES STAINLESS STEEL INTERIOR STANDARD INCLUDING BACK WALL, SHELVES AND DECK PANS**
- **PERFORATED INTERIOR BACK WALL AND TOP FOR IMPROVED AIR FLOW**
- **FRONT AIR INTAKE AND REAR AIR DISCHARGE**
- **STANDARD BACKGUARD IMPROVES AIRFLOW**
- **FOAMED WITH POLYURETHANE, HIGH-DENSITY CELL INSULATION (CFC FREE)**
- **WHITE AND BLACK COLOR COME STANDARD**
- **RECOMMENDED OPERATING CONDITIONS**
 - * TOM Models are designed to operate in an environment where temperature & humidity do not exceed 75°F and 55% respectively.
 - * Units should not be installed near HVAC vents, fans or doorways that will disrupt the air curtain and compromise the function of the cabinet
 - * Air curtain models will run most efficiently when completely loaded with product.

Model	CU./FT.	#of Shelves	HP	AMPS	Crated Weight	L D H
TOM-30S(B)	4.6	3	1/3	9	338	28 x 33 1/2 x 41 1/2
TOM-40S(B)	6.6	3	1/2	11	440	39 x 33 1/2 x 41 1/2
TOM-50S(B)	8.7	3	1/2	11	481	50 3/4 x 33 1/2 x 41 1/2
TOM-60S(B)	10.9	3	3/4	14.5	535	63 1/4 x 33 1/2 x 41 1/2
TOM-75S(B)	13.2	3	3/4	14.5	680	75 5/8 x 33 1/2 x 41 1/2
TOMD-30-H	2.1	1	N/A	N/A	31	28 x 12 1/4 x 17 3/4
TOMD-40-H	3	1	N/A	N/A	40	39 x 12 1/4 x 17 3/4
TOMD-50-H	4	1	N/A	N/A	49	50 3/4 x 12 1/4 x 17 3/4
TOMD-60-H	5	1	N/A	N/A	64	63 1/4 x 12 1/4 x 17 3/4
TOMD-75-H	6.1	2	N/A	N/A	71	75 5/8 x 12 1/4 x 17 3/4

TOM-S/TOMD-H MODELS SPECIFICATIONS

MODEL	TOM-30S(B)	TOM-40S(B)	TOM-50S(B)	TOM-60S(B)	TOM-75S(B)
Exterior Dimension (LxDxH)	28x33 1/2x41 1/2	39x33 1/2x41 1/2	50 3/4x33 1/2x41 1/2	63 1/4x33 1/2x41 1/2	75 5/8x33 1/2x41 1/2
Interior Dimension (LxDxH)	25 1/2x24x13	36 5/8x24x13	48 3/8x24x13	60 3/4x24x13	73 1/2x24x13
Compressor (HP)	1/3	1/2	1/2	3/4	3/4
Voltage (NEMA-5-15P)	115/60/1	115/60/1	115/60/1	115/60/1	115/60/1
AMP	9A	11A	11A	14.5A	14.5A
Plug-In	NEMA 5-15P	NEMA 5-15P	NEMA 5-15P	NEMA 5-15P	NEMA 5-15P
# of Shelves	3 ea	3 ea	3 ea	3 ea	3 ea
Shelf Size (Top)	25 1/2x7x2 1/2	36 1/2x7x2 1/2	48 1/4x14 1/8x3 1/4	60 3/4x14 1/8x3 1/4	73 1/8x14 1/8x3 1/4
(Middle)	25 1/2x14 1/8x3 1/4	36 1/2x14 1/8x3 1/4	48 1/4x14 1/8x3 1/4	60 3/4x14 1/8x3 1/4	73 1/8x14 1/8x3 1/4
(Lower)	25 1/2x9 3/4x3 1/4	36 1/2x14 1/8x3 1/4	48 1/4x14 1/8x3 1/4	60 3/4x14 1/8x3 1/4	73 1/8x14 1/8x3 1/4
Net Weight	255 lbs	313 lbs	370 lbs	440 lbs	498 lbs

MODEL	TOMD-30-H	TOMD-40-H	TOMD-50-H	TOMD-60-H	TOMD-75-H
Exterior Dimension (LxDxH)	28x12 1/4x17 3/4	39x12 1/4x17 3/4	50 3/4x12 1/4x17 3/4	63 1/4x12 1/4x17 3/4	75 5/8x12 1/4x17 3/4
Interior Dimension (LxDxH)	25 1/2x9 1/8x15 7/8	36 5/8x9 1/8x15 7/8	48 3/8x9 1/8x15 7/8	60 3/4x9 1/8x15 7/8	73 1/4x9 1/8x15 7/8
# of Shelves	1 ea	1 ea	1 ea	1 ea	2 ea
Shelf Size	25 1/2x7	36 1/2x7	48 1/4x7	60 3/4x7	36 1/2x7
Net Weight	31 lbs	40 lbs	49 lbs	64 lbs	71 lbs

*Design and specifications subject to change without notice.

■ **WARRANTY : 1 Year Labor and Parts Warranty**
Additional 4 Years Warranty on Compressor

■ **SIMPLE PLUG - IN INSTALLATION**

■ **PATENTED SELF-CONTAINED SYSTEM**
NO PLUMBING REQUIRED

(unit : inch)

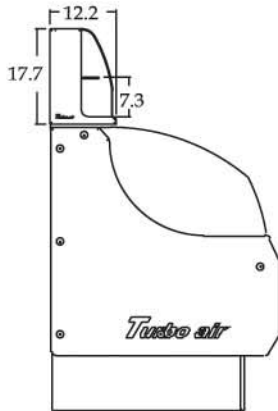

TOM-S COMBINATION WITH TOMD-H
SIDE VIEW

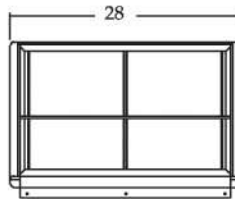

TOMD-30-H PLAN VIEW

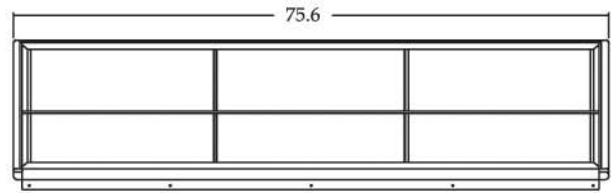

TOMD-75-H PLAN VIEW

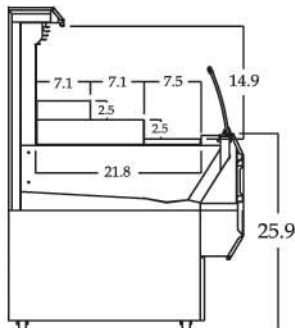

TOM-S SIDE VIEW

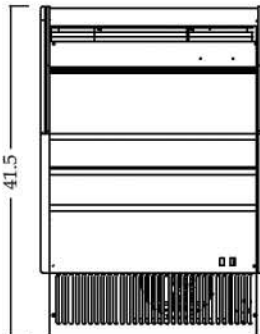

TOM-30S FRONT VIEW

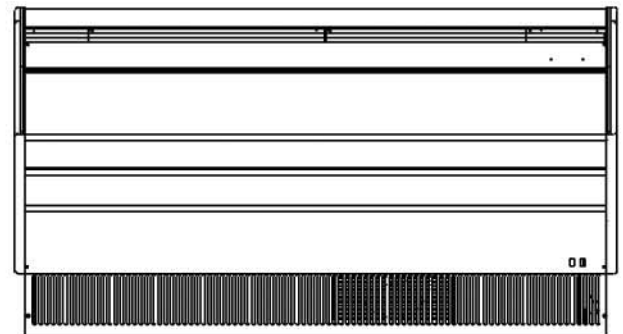

TOM-75S FRONT VIEW

Distributed By:
Commercial Refrigeration Service, Inc.
<http://WWW.IceCubes.NET>
623-869-8881 or toll free 866-IceMakers

NEW

Horizontal Open Display Cases - Low Profile Top Display Dry Case Combination Models



Distributed By:
Commercial Refrigeration Service, Inc.
<http://WWW.IceCubes.NET>
623-869-8881 or toll free 866-IceMakers

FEATURES / BENEFITS

- ENVIRONMENTAL FRIENDLY, EFFICIENT REFRIGERATION SYSTEM**
 Turbo Air's refrigerators are designed with oversized and balanced environmental friendly R-134A (CFC Free) refrigeration. These include large evaporators and condensers for fast cooling and balanced temperature throughout the cabinet.
- ATTRACTIVE GLASS SIDED ELEGANT EURO DESIGN**
 Glass front shield and side walls optimize the merchandiser's display effects of fresh salads, sandwiches, desserts and beverages. Its elegant contemporary euro design will enhance any store application.
- DESIGNED TO OPTIMIZE IMPULSE SALES**
 Ideal for eye-catching displays and convenient access with fast service in high traffic area.
- NON-PEEL, DURABLE ANTI-RUST COATING ON THE EXTERIOR REDUCES FINGERPRINTS**
- TOP DISPLAY DRY CASES (TOMD-L) AVAILABLE IN ALL SIZES-OPTIONAL**
- 300 SERIES STAINLESS STEEL INTERIOR STANDARD INCLUDING BACK WALL, SHELVES AND DECK PANS**
- PERFORATED INTERIOR BACK WALL AND TOP FOR IMPROVED AIR FLOW**
- FRONT AIR INTAKE AND REAR AIR DISCHARGE**
- STANDARD BACKGUARD IMPROVES AIRFLOW**
- FOAMED WITH POLYURETHANE, HIGH-DENSITY CELL INSULATION (CFC FREE)**
- WHITE AND BLACK COLOR COME STANDARD**
- RECOMMENDED OPERATING CONDITIONS**
 * TOM Models are designed to operate in an environment where temperature & humidity do not exceed 75°F and 55% respectively.
 * Units should not be installed near HVAC vents, fans or doorways that will disrupt the air curtain and compromise the function of the cabinet
 * Air curtain models will run most efficiently when completely loaded with product.

Model	CU./FT.	#of Shelves	HP	AMPS	Crated Weight	L D H
TOM-30L(B)	6.1	1	1/3	9	340	28 x 33 1/2 x 45 3/4
TOM-40L(B)	8.8	1	1/2	11	450	39 x 33 1/2 x 45 3/4
TOM-50L(B)	11.7	1	1/2	11	505	50 3/4 x 33 1/2 x 45 3/4
TOM-60L(B)	14.7	1	3/4	14.5	583	63 1/4 x 33 1/2 x 45 3/4
TOM-75L(B)	17.7	2	3/4	14.5	710	75 5/8 x 33 1/2 x 45 3/4
TOMD-30-L	1.5	-	N/A	N/A	27	28 x 12 1/4 x 13 1/4
TOMD-40-L	2.1	-	N/A	N/A	36	39 x 12 1/4 x 13 1/4
TOMD-50-L	2.9	-	N/A	N/A	45	50 3/4 x 12 1/4 x 13 1/4
TOMD-60-L	3.6	-	N/A	N/A	53	63 1/4 x 12 1/4 x 13 1/4
TOMD-75-L	4.3	-	N/A	N/A	64	75 5/8 x 12 1/4 x 13 1/4

TOM-L/TOMD-L MODELS SPECIFICATIONS

MODEL	TOM-30L(B)	TOM-40L(B)	TOM-50L(B)	TOM-60L(B)	TOM-75L(B)
Exterior Dimension (LxDxH)	28x33 1/2x45 3/4	39x33 1/2x45 3/4	50 3/4x33 1/2x45 3/4	63 1/4x33 1/2x45 3/4	75 5/8x33 1/2x45 3/4
Interior Dimension (LxDxH)	25 1/2x24x17 1/2	36 5/8x24x17 1/2	48 3/8x24x17 1/2	60 3/4x24x17 1/2	73 1/4x24x17 1/2
Compressor (HP)	1/3	1/2	1/2	3/4	3/4
Voltage Ⓢ _{NEMA-5-15P}	Ⓢ 115/60/1	Ⓢ 115/60/1	Ⓢ 115/60/1	Ⓢ 115/60/1	Ⓢ 115/60/1
AMP	9A	11A	11A	14.5A	14.5A
Plug-In	NEMA 5-15P	NEMA 5-15P	NEMA 5-15P	NEMA 5-15P	NEMA 5-15P
# of Shelves	1 ea	1 ea	1 ea	1 ea	2 ea
Shelf Size	25 1/2x10 3/4	36 1/2x10 3/4	47 1/4x10 3/4	60 3/4x10 3/4	36 1/2x10 3/4
Net Weight	257 lbs	317 lbs	376 lbs	448 lbs	507 lbs

MODEL	TOMD-30-L	TOMD-40-L	TOMD-50-L	TOMD-60-L	TOMD-75-L
Exterior Dimension (LxDxH)	28x12 1/4x13 1/4	39x12 1/4x13 1/4	50 3/4x12 1/4x13 1/4	63 1/4x12 1/4x13 1/4	75 5/8x12 1/4x13 1/4
Interior Dimension (LxDxH)	25 1/2x9 1/8x11 3/8	36 5/8x9 1/8x11 3/8	48 3/8x9 1/8x11 3/8	60 3/4x9 1/8x11 3/8	73 1/4x9 1/8x11 3/8
Net Weight	27 lbs	36 lbs	45 lbs	53 lbs	64 lbs

*Design and specifications subject to change without notice.

- **WARRANTY :** 1 Year Labor and Parts Warranty
Additional 4 Years Warranty on Compressor

(unit : inch)

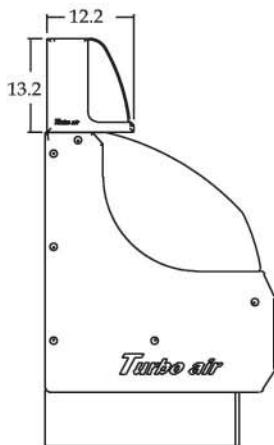

TOM-L COMBINATION WITH TOMD-L
SIDE VIEW

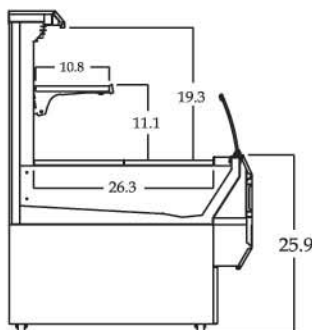

TOM-L SIDE VIEW

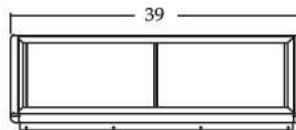

TOMD-40-L PLAN VIEW

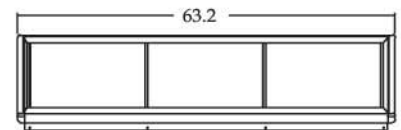

TOMD-60-L PLAN VIEW

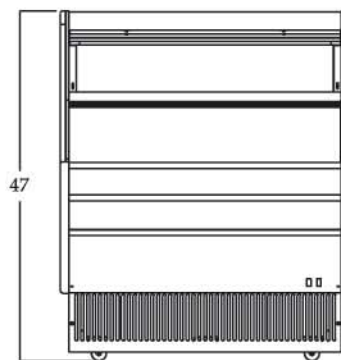

TOM-40L FRONT VIEW

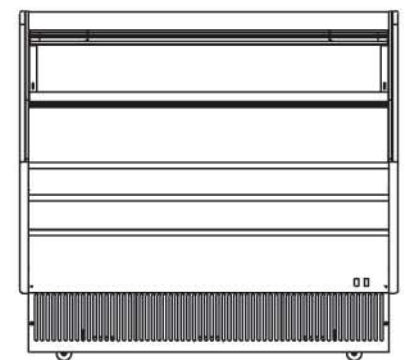

TOM-60L FRONT VIEW

Distributed By:
Commercial Refrigeration Service, Inc.
<http://WWW.IceCubes.NET>
623-869-8881 or toll free 866-IceMakers

NEW

**Vertical Open Display Cases - Medium & Full Heights
 Energy Saving Night Curtain (TOM-40 & 50)**

Distributed By:
 Commercial Refrigeration Service, Inc.
<http://WWW.IceCubes.NET>
 623-869-8881 or toll free 866-IceMakers



FEATURES / BENEFITS

- **ENVIRONMENTAL FRIENDLY, EFFICIENT REFRIGERATION SYSTEM**
 Turbo Air's refrigerators are designed with oversized and balanced environmental friendly R-404A (CFC Free) refrigeration. These include large evaporators and condensers for fast cooling and balanced temperature throughout the cabinet.
- **ATTRACTIVE GLASS SIDED ELEGANT EURO DESIGN**
 Glass front shield and side walls optimize the merchandiser's display effects of fresh salads, sandwiches, desserts and beverages. Its elegant contemporary euro design will enhance any store application.
- **DESIGNED TO OPTIMIZE IMPULSE SALES**
 Ideal for eye-catching displays and convenient access with fast service in high traffic area.
- **NON-PEEL, DURABLE ANTI-RUST COATING ON THE EXTERIOR REDUCES FINGERPRINTS**
- **ENERGY SAVING NIGHT CURTAIN STANDARD (TOM-40 & TOM-50 ONLY)**
- **STANDARD BACKGUARD IMPROVES AIRFLOW**
- **FOAMED WITH POLYURETHANE, HIGH-DENSITY CELL INSULATION (CFC FREE)**
- **300 SERIES STAINLESS STEEL INTERIOR STANDARD INCLUDING BACK WALL, SHELVES AND DECK PANS**
- **PERFORATED INTERIOR BACK WALL AND TOP FOR IMPROVED AIR FLOW**
- **FRONT AIR INTAKE AND REAR AIR DISCHARGE**
- **FLUORESCENT LIGHTING ON EACH SHELF**
- **WHITE AND BLACK COLOR COME STANDARD**
- **RECOMMENDED OPERATING CONDITIONS**

 - * TOM Models are designed to operate in an environment where temperature & humidity do not exceed 75°F and 55% respectively.
 - * Units should not be installed near HVAC vents, fans or doorways that will disrupt the air curtain and compromise the function of the cabinet
 - * Air curtain models will run most efficiently when completely loaded with product.

Model	CU./FT.	#of Shelves	HP	AMPS	Crated Weight	L D H
TOM-40M(B)	10.6	3	1	15	521	39 x 27 1/4 x 60
TOM-50M(B)	14.1	3	1	15	567	50 3/4 x 27 1/4 x 60
TOM-40(B)	14.7	4	1	15	543	39 x 27 1/4 x 78
TOM-50(B)	19.6	4	1	15	629	50 3/4 x 27 1/4 x 78

TOM-M/TOM MODELS SPECIFICATIONS

MODEL	TOM-40M(B)	TOM-50M(B)	TOM-40(B)	TOM-50(B)
Exterior Dimension (LxDxH)	39x27 1/4x60	50 3/4x27 1/4x60	39x27 1/4x78	50 3/4x27 1/4x78
Interior Dimension (LxDxH)	36 1/2x15x33 7/8	48 3/8x14 1/4x33 7/8	36 1/2x14 1/4x49 7/8	48 3/8x14 1/4x49 7/8
Compressor (HP)	1	1	1	1
Voltage (NEMA 5-20P)	115/60/1	115/60/1	115/60/1	115/60/1
AMP	15 A	15 A	15 A	15 A
Plug-In	NEMA 5-20P	NEMA 5-20P	NEMA 5-20P	NEMA 5-20P
#of Shelves	3	3	4	4
Shelf Size	35 3/4x8 3/4 35 3/4x9 3/4 35 3/4x10 3/4	47 3/4x8 3/4 47 3/4x9 3/4 47 3/4x10 3/4	35 3/4x10 3/4 35 3/4x10 3/4 35 3/4x10 3/4 35 3/4x10 3/4	47 3/4x10 3/4 47 3/4x10 3/4 47 3/4x10 3/4 47 3/4x10 3/4
Net Weight	421 lbs	463 lbs	512 lbs	590 lbs

*Design and specifications subject to change without notice.

■ **WARRANTY : 1 Year Labor and Parts Warranty**
Additional 4 Years Warranty on Compressor

Distributed By:
Commercial Refrigeration Service, Inc.
<http://WWW.IceCubes.NET>
623-869-8881 or toll free 866-IceMakers

(unit : inch)

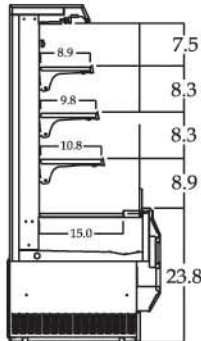

TOM-40M/50M SIDE VIEW

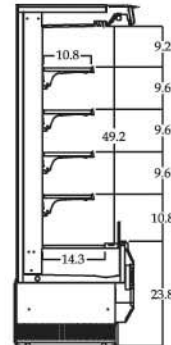

TOM-40/50 SIDE VIEW

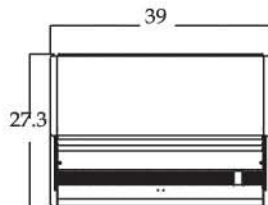

TOM-40M

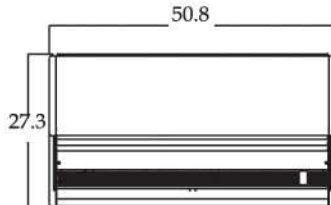

TOM-50M

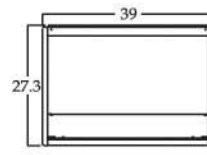

TOM-40 PLAN VIEW

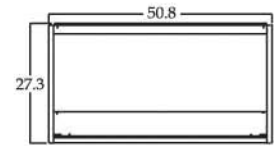

TOM-50 PLAN VIEW

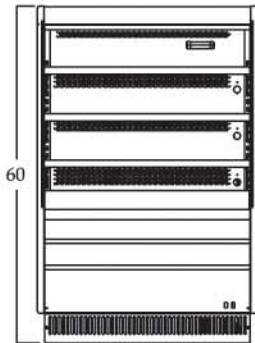

TOM-40M FRONT VIEW

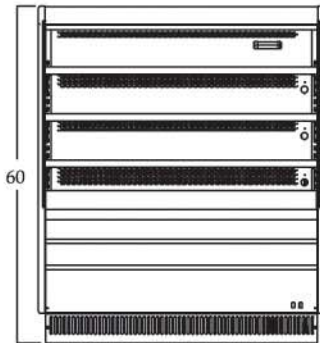

TOM-50M FRONT VIEW

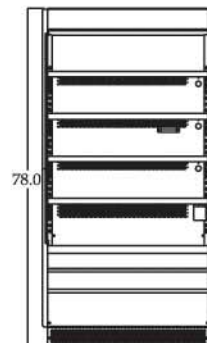

TOM-40 FRONT VIEW

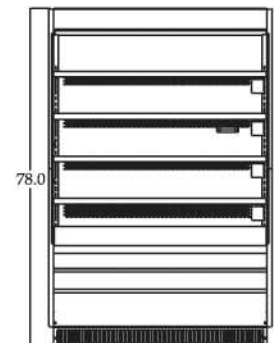

TOM-50 FRONT VIEW